

B E V E L G E A R S C R E W J A C K S

BEVEL GEAR SCREW JACK SYSTEMS

JACK MODELS

Nook/Thomson Bevel Gear Screw Jack systems are ruggedly designed using a ground spiral bevel gear and produced in standard models with load handling capacities from 12.3kN to 117kN. They may be used individually or in multiple arrangements. There are no "standard" travel lengths and each bevel gear screw jack is built to specification. All bevel gear screw jacks are equipped with hardened and sharpened spiral toothed bevel gear transmissions for high lifting speed and greater duty cycle.

The Bevel Gear Screw jack housings are made from AISI Class 30 gray cast iron. The input shafts are either AISI 5210 alloy steel for the 2:1 ratios, or AISI 1045 alloy steel for the 3:1 ratios. The lift shafts are made from AISI 1055 alloy steel. The bevel jacks are shipped with a zinc phosphate coating and can be painted upon request.

MACHINE SCREW JACKS

Bevel Gear Machine Screw Jacks incorporate the use of a trapezoidal screw. The acme screw conforms to DIN 103 standard with a low backlash between the nut and screw.

BALL SCREW JACKS

Bevel Gear Ball Screw Jacks use a ball screw and nut made from hardened alloy steel with hardened bearing balls carrying the load between the nut and the screw permitting smooth and efficient movement of the load. Because of the greater efficiency and rolling action, the ball screw can operate at higher speeds or increased duty cycle when compared with the Machine Screw Jack. The addition of a high efficiency ball screw and nut reduces the required input torque to approximately one-third the torque required for the Machine Screw Jack.

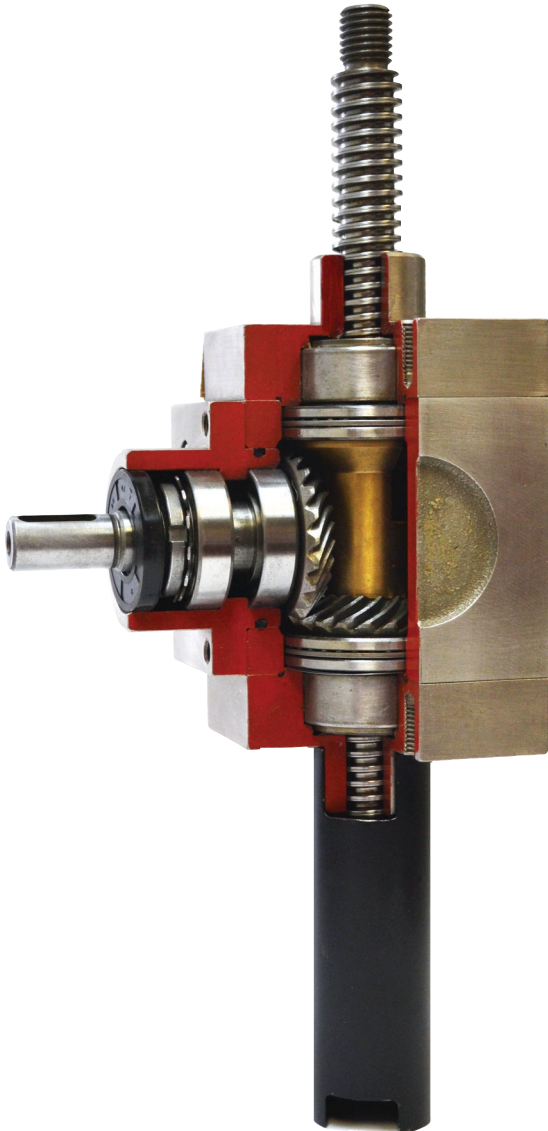

JACK CONFIGURATIONS

TRANSLATING JACKS

A translating jack has a lifting shaft that moves through the gear box. A nut is integrated with the bevel gear such that the bevel gear and nut rotate together. When the lift shaft is held to prevent rotation, the lift shaft will move linearly through the gear box to move the load.

ROTATING JACKS

A rotating jack has a lift shaft that moves a nut as it turns. The lift shaft is fixed to the bevel gear. This causes the load, which is attached to the travel nut, to move along the lift shaft.

KEYED JACKS

The lift shaft of a translating style jack must be attached to something which prevents the lift shaft from rotating. If it is not, the lift shaft (and the load) will turn and not translate. A feature can be added to a machine screw jack to prevent lift shaft rotation. This type of jack is referred to as a "keyed jack" and is available in translating models. Anti-rotation is accomplished by a square guide attached to the screw translating inside a square stem cover attached to the jack. The square stem tube is supplied with lube fittings.



TRANSLATING



ROTATING

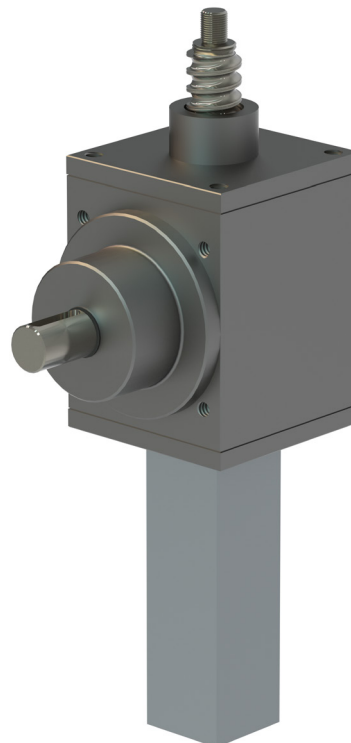

KEYED

DEFINITIONS AND TECHNICAL DATA

TRAVEL LENGTH

Jacks are not pre-assembled or stocked with standard length screws. Each jack is made to order based on travel length. Nook/Thomson has the capability to manufacture long screws for special applications, limited only by the availability of raw materials. Rotating screw jacks may be assembled with a larger diameter lift screw for greater column strength.

INPUT TORQUE

The input torque is the rotary force required at the input of the jack to generate an output force at the lift shaft. The product specification pages show the torque necessary to raise per one kN. This number multiplied by the load is the required input torque.

Due to static friction, starting or "breakaway" torque can be as much as two to three times running torque. If the load is moved horizontally, the force required to move the load will be lessened in proportion to the coefficient of friction of the surface along which the load is moved. In addition, the force needed to start, stop and hold the load (inertia loading) is provided by the jack. Jack sizing should consider all these forces. If an application calls for several jacks to be driven together in series, the first jack should be limited to three times the rated Maximum Input Torque, as listed in the Jack Selection chart for the particular selected jack. For multiple high lead ball screw jacks or belt/chain driven jacks contact Nook/Thomson for allowable input torque values. Multiple jacks driven in a series may require operation at reduced load.

TARE DRAG TORQUE

The gear box components (bearings, seals and oil) in a jack add "tare drag." The product specification pages show the tare drag torque. Tare drag should be considered when calculating total torque required.

INPUT SPEED

Bevel Gear Screw Jacks are rated for up to 3,000 rpm input speed, provided kilowatt and temperature ratings are not exceeded. A speed-factor must be applied when input speeds are greater than 1500 rpm. (see page 8) Contact Nook/Thomson engineers if higher input speeds are required.

DUTY CYCLE

Duty cycle is the ratio of run time to total cycle time. Some of the mechanical energy input to a Bevel Gear screw jack is converted into heat caused by friction. The duty cycle is limited by the ability of the Bevel Gear screw jack to dissipate heat. An increase in temperature can affect the properties of some components resulting in accelerated wear, damage and possible unexpected failure.

Consult pages 8 and 9 for efficiency speed/load graph to best determine the proper duty cycle for your given application.

SELF-LOCKING AND BRAKES

Self-locking occurs when system efficiencies are low enough that the force on the lifting shaft cannot cause the drive system to reverse direction. All bevel screw jacks can back drive and require some means of holding the load, such as a brake on the motor. The product specification pages show holding torque values. Holding torque represents the amount of input torque required to restrain the load.

In addition to back driving, system inertia usually results in some over travel when the motor is switched off. The inertia of the system should be considered when determining the brake size required to stop a dynamic load.

TEMPERATURE

All Bevel Gear Screw Jacks are suitable for operation within the specified limits provided that the housing temperature is not lower than 0°C or higher than 90°C. For higher or lower operating temperature ranges contact Nook/Thomson.

Housing temperature should be monitored and kept below 90°C maximum. Continuous or heavy duty operation is possible by derating the jack capacity, external cooling of the unit or through the use of a recirculating lubrication system.

TRAVEL STOPS

Travel stops are not standard. A limit switch and a brake should be used to stop the motor. Mechanical stops can cause damage to the jacks because most electric motors will deliver stall torques much higher than their rated torques and motor inertia can cause severe shock loads. For hand operation, mechanical stops can be provided.

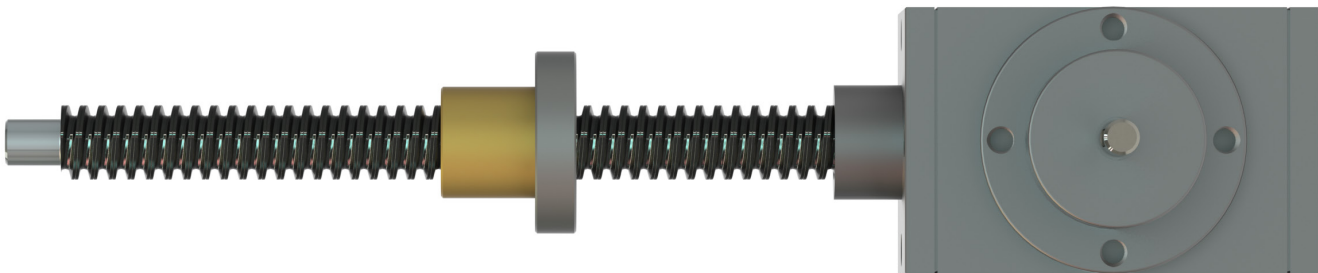

DESIGN CONSIDERATIONS

BALL SCREW VS. MACHINE SCREW JACK

The decision to use a ball screw jack or a machine screw jack is based on the application. For many applications, a ball screw model is the best choice. Ball screw jacks are more efficient and therefore require less power than a machine screw jack in the same application.

For low duty cycle applications, for hand-operated applications, or if back driving is not acceptable consider a machine screw jack.

Bevel Gear Ball Screw Jacks are preferred for:

- Long travel lengths
- Long, predictable life
- High duty cycles
- Oscillating motion

Bevel Gear Machine Screw Jacks are preferred for:

- Vibration environments
- Manual operation
- High static loads

JACK SIZING CONSIDERATIONS

Jacks are limited by multiple constraints: load capacity, duty cycle, kilowatt, column strength, critical speed, type of guidance, brakemotor size, and ball screw life. To size a screw jack for these constraints, application information must be collected.

LOAD CAPACITY

The load capacity of the jack is limited by the physical constraints of its components (drive sleeve, lift shaft, bearings, etc.). All anticipated loads should be within the rated capacity of the jack. Loads on the jack in most applications include: static loads, dynamic or moving loads, cutting forces or other reaction forces and acceleration/deceleration loads.

For shock loads, the peak load must not exceed the rated capacity of the jack, and an appropriate design factor should be applied that is commensurate with the severity of the shock.

Total Load - The total load includes static loads, dynamic loads and inertia loads from acceleration and deceleration. Also consider reaction forces received from the load such as drilling or cutting forces when using a jack to move a machine tool.

For multiple jack systems, load distribution should be considered. System stiffness, center of gravity, drive shaft windup and lead variation in the lift shafts may result in unequal load distribution.

Number of Jacks - The number of jacks used depends on physical size and design of the equipment. Stiffness of the equipment structure and guide system will determine the appropriate number of jacks required. Fewer jacks are easier to drive, align and synchronize.

KILOWATT RATINGS

The kilowatt limit of the jack is a result of the ability to dissipate the heat generated from the inefficiencies of its components. Kilowatt is calculated by using the following formula:

$$\text{kW per jack} = \left(\frac{\left(\begin{array}{l} \text{Torque to} \\ \text{raise one} \\ \text{kN(N} \bullet \text{m)} \end{array} \right) \times \left(\begin{array}{l} \text{Number} \\ \text{of kN} \\ \text{to be raised} \end{array} \right) + \begin{array}{l} \text{Tare} \\ \text{Drag} \\ \text{Torque} \end{array} \right) \times \text{RPM} \\ 9,549$$

The product specification pages show the "torque to raise one kN" value for each jack.

Kilowatt values are influenced by many application specific variables including mounting, environment, duty cycle and lubrication. The best way to determine whether performance is within kilowatt limits is to measure the jack temperature. The temperature of the housing near the input shaft must not exceed 90°C.

COLUMN STRENGTH

Column strength is the ability of the lift shaft to hold compressive loads without buckling. With longer screw lengths, column strength can be substantially lower than nominal jack capacity.

If the lift shaft is in tension only, the screw jack travel is limited by the available screw material or by the critical speed of the screw. Refer to the acme screw and ball screw technical sections for critical speed limitations. If there is any possibility for the lift shaft to go into compression, the application should be sized for sufficient column strength.

Charts are provided to determine the required jack size in applications where the lift shaft is loaded in compression. To use the charts (pages 6 and 7, find a point at which the maximum length "L" intersects the maximum load. Be sure the jack selected is above and to the right of that point.

Maximum Length – The maximum length includes travel, housing length, starting/stopping distance, extra length for boots and length to accommodate attachment of the load.

If column strength is exceeded for the jack selected, consider the following options:

- Change the jack configuration to put the lift shaft in tension
- Increase size of jack.
- Add a bearing mount (like the EZZE-MOUNT™) for rotating jacks.
- Change the lift shaft mounting condition (e.g. from clevis to top plate).

CAUTION: Chart does not include design factors.

The charts assume proper jack alignment with no bending loads on the screw. Effects from side loading are not included in this chart. Jacks operating horizontally with long lift shafts can experience bending from the weight of the screw.

COLUMN STRENGTH CHARTS

BALL SCREW JACKS

Column strength is the ability of the lift shaft to hold compressive loads without buckling. With longer screw lengths, column strength may be substantially lower than nominal jack capacity.

If the lift shaft is in tension only, the screw jack travel is limited by the available screw material or by the critical speed of the screw. Refer to the ball screw technical section for critical speed limitations. If there is any possibility for the lift shaft to go into compression, the application should be sized for sufficient column strength.

The chart below is used to determine the required jack size in applications where the lift shaft is loaded in compression.

To use this chart: Find a point at which the maximum length "L" intersects the maximum load. Be sure the jack selected is above and to the right of that point.

CAUTION: Chart does not include a design factor.

The chart assumes proper jack alignment with no bending loads on the screw. Effects from side loading are not included in this chart. Jacks operating horizontally with long lift shafts can experience bending from the weight of the screw. Consult Nook/Thomson if side thrust is anticipated, operating horizontally, or maximum raise is greater than 30 times the screw diameter.

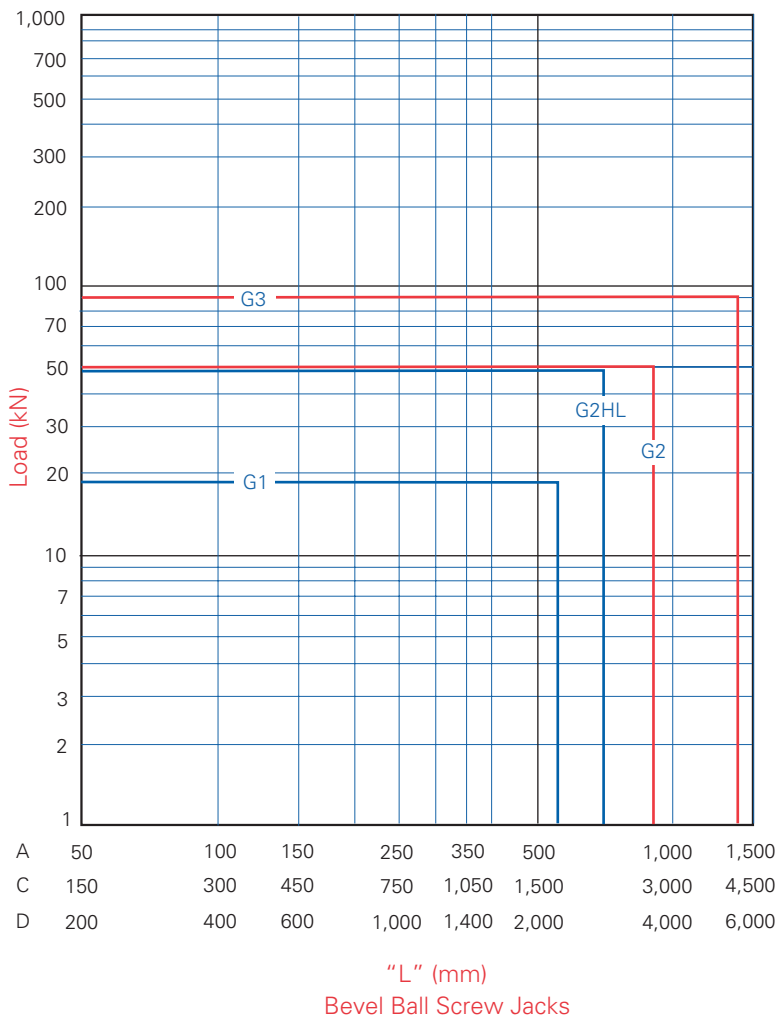

MOUNTING CONDITIONS

A

ONE END FIXED
ONE END FREE

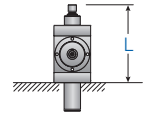

C

ONE END FIXED,
ONE END
SUPPORTED
(CLEVIS
ATTACHED TO
GUIDE STRUCTURE)

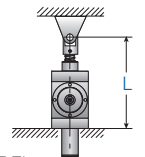

ONE END FIXED,
ONE END
SUPPORTED
(RADIAL BEARING))

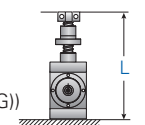

D

BOTH ENDS FIXED
(TOP PLATE
ATTACHED TO
GUIDED
STRUCTURE)

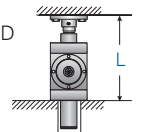

MACHINE SCREW JACKS

Column strength is the ability of the lift shaft to hold compressive loads without buckling. With longer screw lengths, column strength may be substantially lower than nominal jack capacity.

If the lift shaft is in tension only, the screw jack travel is limited by the available screw material or by the critical speed of the screw. Refer to the trapezoidal screw technical section for critical speed limitations. If there is any possibility for the lift shaft to go into compression, the application should be sized for sufficient column strength.

The chart below is used to determine the required jack size in applications where the lift shaft is loaded in compression.

To use this chart: Find a point at which the maximum length "L" intersects the maximum load. Be sure the jack selected is above and to the right of that point.

CAUTION: chart does not include a design factor.

The chart assumes proper jack alignment with no bending loads on the screw. Effects from side loading are not included in this chart. Jacks operating horizontally with long lift shafts can experience bending from the weight of the screw. Consult Nook/Thomson if side thrust is anticipated, operating horizontally, or maximum raise is greater than 30 times the screw diameter.

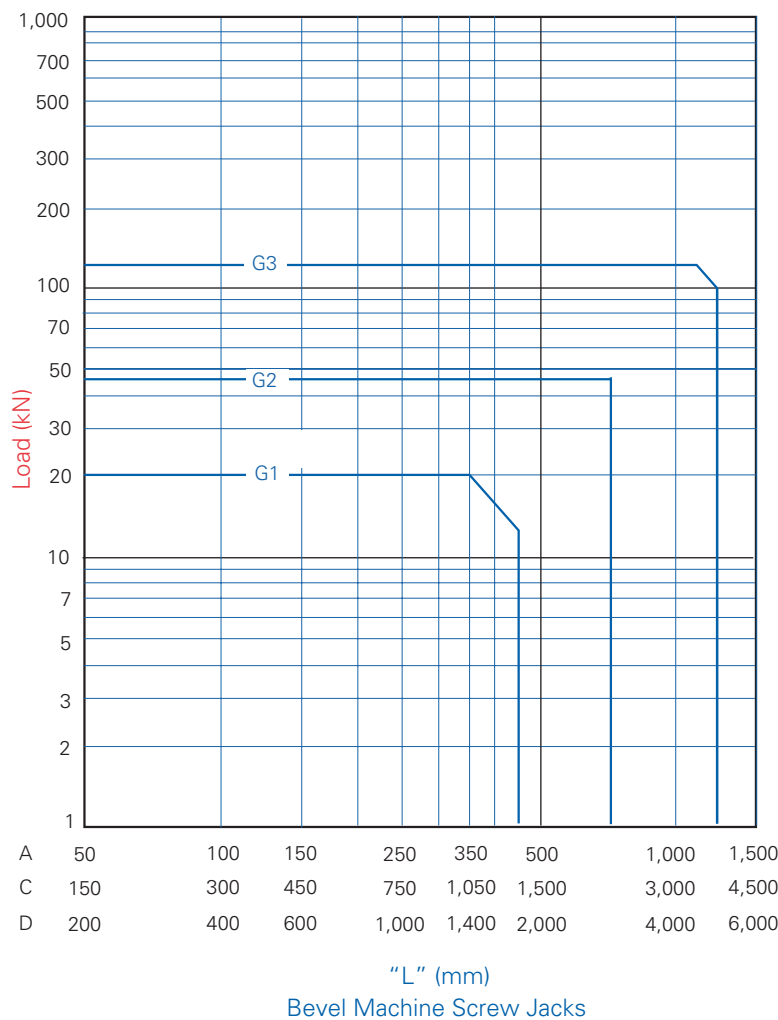

MOUNTING CONDITIONS

A

ONE END FIXED
ONE END FREE

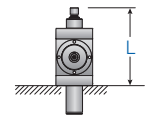

C

ONE END FIXED,
ONE END
SUPPORTED
(CLEVIS
ATTACHED TO
GUIDE STRUCTURE)

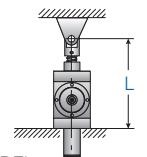

ONE END FIXED,
ONE END
SUPPORTED
(RADIAL BEARING))

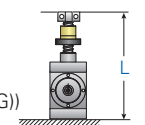

D

BOTH ENDS FIXED
(TOP PLATE
ATTACHED TO
GUIDED
STRUCTURE)

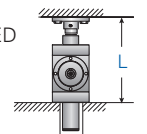

DUTY CYCLE CHARTS

BALL SCREW JACKS

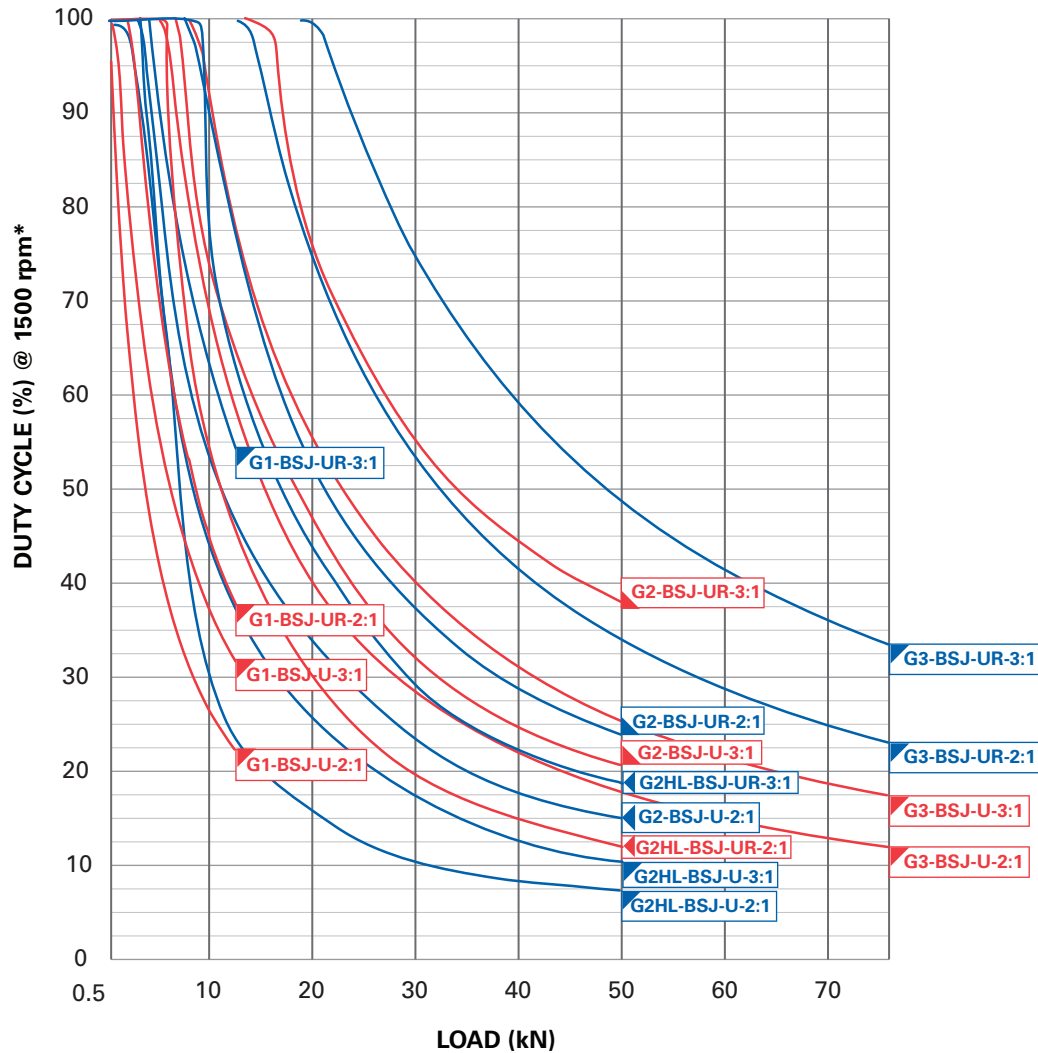

*Chart is based on 20°C Ambient Temp.

To calculate the operating time for other speeds and temperatures, multiply the duty cycle in % by f_n and f_t .

SPEED	SPEED FACTOR f_n	AMBIENT TEMP (C)	TEMP FACTOR f_t
3000	0.5	0°	1.5
2500	0.6	10°	1.2
2000	0.75	20°	1.0
1000	1.5	30°	0.8
750	2	40°	0.6
500	3	50°	0.4
250	6	60°	0.2

If different speeds determine the average of speed:

$$(n_m = n_1 * q_1 + n_2 * q_2 + \dots n_i * q_i) / 100$$

n_1, n_2, \dots = Each incremental speed movement in rpm

q_1, q_2, \dots = Percentage of move time

n_m = Average speed in rpm

Max temp 70°C at Gear Box

MACHINE SCREW JACKS

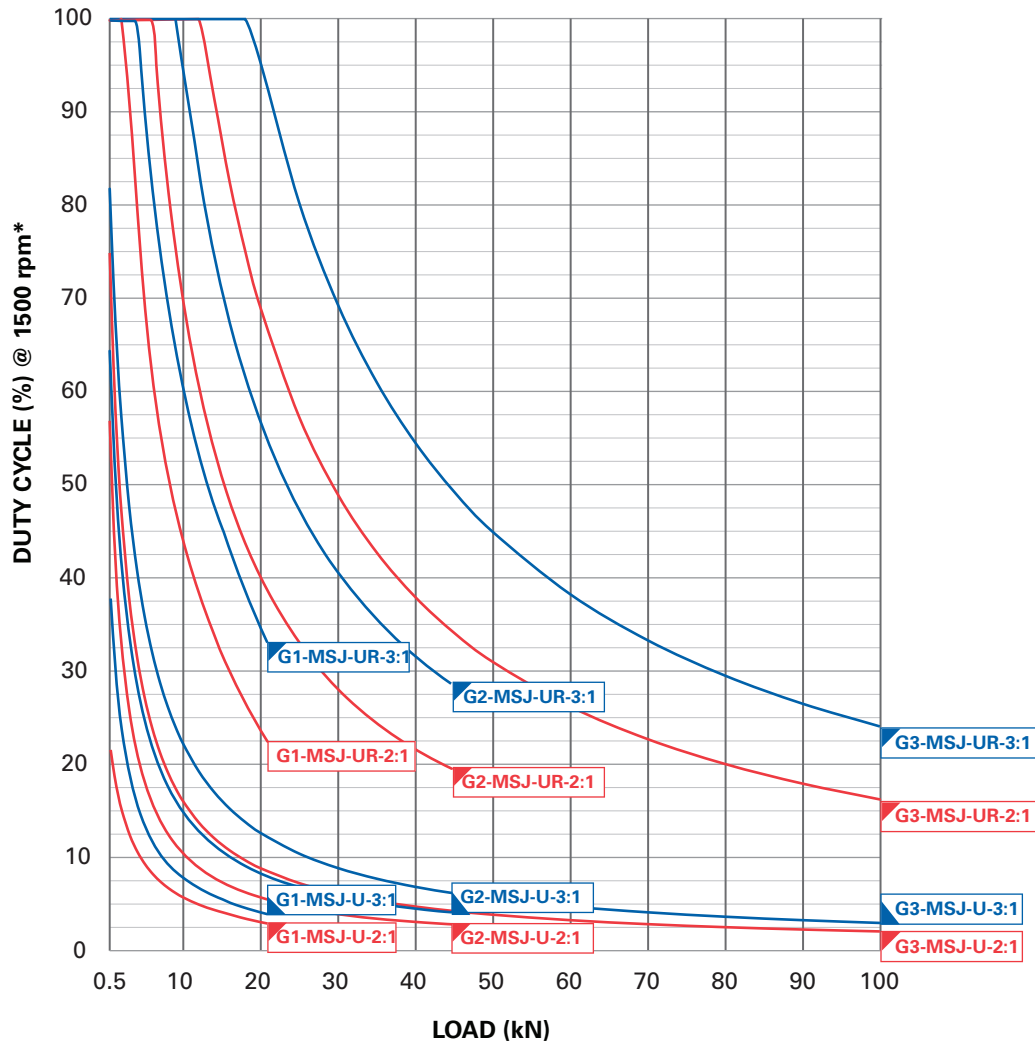

*Chart is based on 20°C Ambient Temp.

To calculate the operating time for other speeds and temperatures, multiply the duty cycle in % by f_n and f_t .

SPEED	SPEED FACTOR f_n	AMBIENT TEMP (C)	TEMP FACTOR f_t
3000	0.5	0°	1.5
2500	0.6	10°	1.2
2000	0.75	20°	1.0
1000	1.5	30°	0.8
750	2	40°	0.6
500	3	50°	0.4
250	6	60°	0.2

If different speeds determine the average of speed:

$$(n_m = n_1 * q_1 + n_2 * q_2 + \dots n_i * q_i) / 100$$

n_1, n_2, \dots = Each incremental speed movement in rpm

q_1, q_2, \dots = Percentage of move time

n_m = Average speed in rpm

Max temp 70°C at Gear Box

DESIGN CONSIDERATIONS (CONTINUED)

CRITICAL SPEED

The speed that excites the natural frequency of the screw is referred to as the critical speed. Resonance at the natural frequency of the screw will occur regardless of the screw orientation or configurations of the jack (vertical, horizontal, translating, rotating, etc.). The critical speed will vary with the diameter, unsupported length, end fixity and rpm of the screw. Since critical speed can also be affected by the shaft straightness and assembly alignment, it is recommended that the maximum speed be limited to 80% of the calculated critical speed.

Because of the nature of most screw jack applications, critical speed is often overlooked. However, with longer travels, critical speed should be a major factor in determining the appropriate size jack. Refer to Nook/Thomson Precision Screw Assemblies Design Guide to best determine the appropriate critical speed for a particular jack selection.

TRAVEL RATE

Establishing a travel rate allows for evaluation of critical speed and kilowatt limits. Acceleration/deceleration time needs to be considered when determining maximum required travel rate.

TYPE OF GUIDANCE

Linear motion systems require both thrust and guidance. Jacks are designed to provide thrust only and provide insufficient guidance support. The guidance system must be designed to absorb all loads other than thrust.

Nook/Thomson can provide either hardened ground round shafting or square profile rail to support and guide linear motion systems.

BRAKEMOTOR SIZING

Safety is the most important consideration. A brake motor is recommended for all Bevel Gear products where there is a possibility of injury.

The kilowatt requirements determine the size of the motor. Upon selecting a brake motor, verify that the standard brake has sufficient torque to both hold the load and stop the load.

CAUTION: High lead ball screw jacks may require larger nonstandard brakes to stop the load. An appropriately sized brake will insure against excessive "drift" when stopping for both the Ball Screw and Machine Screw Jacks.

REQUIRED APPLICATION DATA

Load

- Total Maximum Thrust Load on Jacks
- Total Maximum Thrust Load on any one Jack
- Number of Jacks

Travel

- Length in millimeters
- Orientation (vertical, horizontal, arc, diagonal, etc.)
- Travel Rate
- Optimal Speed
- Minimal Acceptable Speed
- Maximum Acceptable Speed

Duty Cycle

- Distance Per Cycle
- Number of cycles per time period
- Maximum Distance Traveled in any Year
- Life Desired

Configuration

- Tension, Compression, or both
- Driven by Hand, Motor, or Other
- Translating, Rotating

For dimension information, please refer to the guides online at www.nookindustries.com.

LIFE EXPECTANCY

DEFINITIONS - The dynamic load ratings shown on the product specification pages indicate the load that can be carried for 1 million revolutions based on 90% reliability.

The charts on pages 11 relate life to load. In applications where the load and rotational speed is relatively constant over the entire stroke, use the highest load in selecting a ball screw to provide a factor of extra life. For applications where the loads and/or rotational speed vary significantly, an equivalent load can be calculated using the following formula:

$$F_m = \sqrt[3]{\sum_{j=1}^n F_j^3 \times \frac{n_j}{n_m} \times \frac{q_j}{100}}$$

WHERE:

- F_m = equivalent axial load (N)
- F_j = each increment of axial load (N)
- q_j = percent of stroke at load F_j
- n_j = rotational speed at load F_j (rpm)
- n_m = equivalent rotational speed (rpm) and is given by the following equation:

$$n_m = \sum_{j=1}^n \frac{q_j}{100} \times n_j$$

LIFE (REVS)

The life required in revolutions is determined by multiplying the total stroke in millimeters by the total number of strokes required for the designed life of the equipment and then dividing by the lead of the ball nut. Ball nut life is greatly influenced by the operating condition, including speed and vibration the assembly may see. A fatigue factor must be considered when calculating life. To calculate the life for a ball nut use the following formula:

$$L = \left(\frac{C_a}{F_m \times f_w} \right)^3 \times 10^6$$

WHERE:

- L = Life measured in revolutions
- C_a = Basic Dynamic Load Rating
- F_m = equivalent axial load (N)
- f_w = Fatigue Factor

OPERATION CONDITION	f_w (FATIGUE FACTOR)
No External Vibration	1.0 - 1.2
Indirect Vibration	1.2 - 1.5
Direct Vibration OR High Cyclical Impact	1.5 - 2.5
Direct Vibration AND High Cyclical Impact	2.5 - 3.5

INDIRECT VIBRATION - Any vibration associated near the screw mounting which influences the stability of the assembly.

DIRECT VIBRATION - Any vibration directly linked to the screw assembly which influences the stability of the assembly.

HIGH CYCLICAL IMPACT - Any repetitive impact or high deceleration of the ball screw assembly.

LIFE (ADJUST TO RELIABILITY)

If operation reliability higher than 90% is required, then the theoretical life must be corrected by using a reliability factor (f_{ar}) according to the table.

$$L_{ar} = L \times f_{ar}$$

RELIABILITY (%)	f_{ar}
90	1
95	0.62
96	0.53
97	0.44
98	0.33
99	0.21

LIFE (HOURS)

If total time is needed, the following equation can be used to find the life measured in hours:

$$L_h = \frac{L}{60 \times n_m}$$

QUICK REFERENCE

BALL SCREW BEVEL GEAR JACKS

	Gear Ratio	Capacity (kN)	Lifting Screw Dia (mm)	Screw lead (mm)	Raise for One Turn of Worm (mm)	Max Input Torque (N-m)	Torque to Raise 1 kN (N-m)	Back Drive Holding Torque (N-m)	Tare Drag Torque* (N-m)	Dynamic Load Ca (kN)
G1	2:1	15	25	5	2.5	50	0.53	2.68	1.8	2.3
	3:1	15	25	5	1.6	50	0.34	1.16	1.7	2.3
G2	2:1	50	40	5	2.5	175	0.53	9.64	2.3	23.8
	3:1	50	40	5	1.6	175	0.34	5.44	2.2	23.8
G2-HL	2:1	50	32	10	5	175	1.06	21.57	2.3	33.4
	3:1	50	32	10	3.33	175	0.71	13.70	2.2	33.4
G3	2:1	90	63	10	5	1600	1.06	38.57	4.4	76.0
	3:1	90	63	10	3.33	1600	0.71	31.47	4.3	76.0

MACHINE SCREW BEVEL GEAR JACKS

	Gear Ratio	Capacity (kN)	Lifting Screw Dia (mm)	Screw lead (mm)	Raise for One Turn of Worm (mm)	Max Input Torque (N-m)	Torque to Raise 1 kN (N-m)	Back Drive Holding Torque (N-m)	Tare Drag Torque* (N-m)
G1	2:1	20.6	24	5	2.5	50	0.88	1.06	1.8
	3:1	20.6	24	5	1.6	50	0.57	0.13	1.7
G2	2:1	44.5	40	7	3.5	175	1.39	6.61	2.3
	3:1	44.5	40	7	2.3	175	0.93	3.73	2.2
G3	2:1	117	60	9	4.5	1600	2.05	13.65	4.4
	3:1	117	60	9	3	1600	1.36	7.73	4.3

* Tare Drag Torque is based on elevated oil temperature due to the operation of the jack. Expect Tare Drag values to be double at startup with ambient oil temperatures.

REFERENCE NUMBER SYSTEM

BEVEL GEAR JACKS

G2-BSJ- U 2:1 / SSE-1 / 000-2 / UD/ FT / 580 / BS

JACK MODEL

Model #
G1-BSJ G1-MSJ
G2-BSJ G2-MSJ
G2HL-BSJ G3-MSJ
G3-BSJ

CONFIGURATION

U = Upright
UR = Upright Rotating
UK = Upright Keyed

GEAR RATIO

Refer to product pages for available ratios.

SHAFT ORDER CODE

SSE-1/000-2 = ONE Shaft Input
SSE-1/SSE-2 = TWO Shaft Inputs (180°)
SSE-1/SSX-2 = TWO Shaft Inputs (90°)
For additional input shafts, contact Nook Engineering.

INPUT ROTATION

U = Input(s) CW, Extends Lifting Shaft
Z = Input(s) CCW, Extends Lifting Shaft

PORT LOCATION

C-F See page 13.

HOUSING CONFIGURATION

F = Standard Flange Base
T = Trunion

SCREW CONFIGURATION

TRANSLATING - U and UK Models
T = Standard Threaded End
C = Clevis End D = Female Clevis End
P = Top Plate R = Rodeye Clevis

ROTATING - UR Models
A = Travel Nut Position A
B = Travel Nut Position B



Travel Nuts shown in position A.

TRAVEL

For Translating Screw Models (U, UK) use actual travel in mm.
For Rotating Screw Models (UR) use "L" dimension in mm.

MODIFIER LIST

B = Optional Bellows Boots (Must calculate retracted and extended boot length.)

S or M Required
S = Standard, no additional description required
M = Modified, additional description required

INPUT ROTATION

The input shafts can either rotate CW or CCW with respect to extending the lift shaft. Care must be taken when using multiple jack arrangements. Bevel Jacks with two input shafts will rotate in opposing direction with respect to their common axis. See page 14 for multiple jack arrangements.

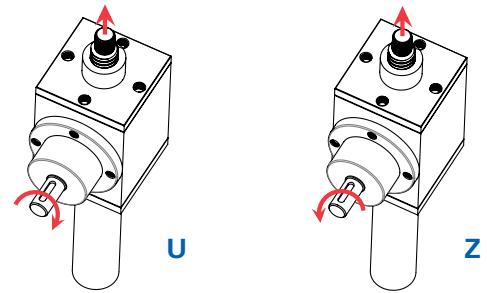

PORT LOCATION

The bevel jacks are oil filled and are fitted with an oil vent. The bevel jacks come with four port plugs located on the same surface. When ordering, specify which surface the ports are to be located. After installation, replace the upper most port plug with the supplied oil vent. The oil level is half the volume of the gear box housing. The oil vent needs to be located in the port that is above the oil line to prevent leakage. If the vent is not properly installed excessive pressure will build in the gearbox housing and leakage can occur.

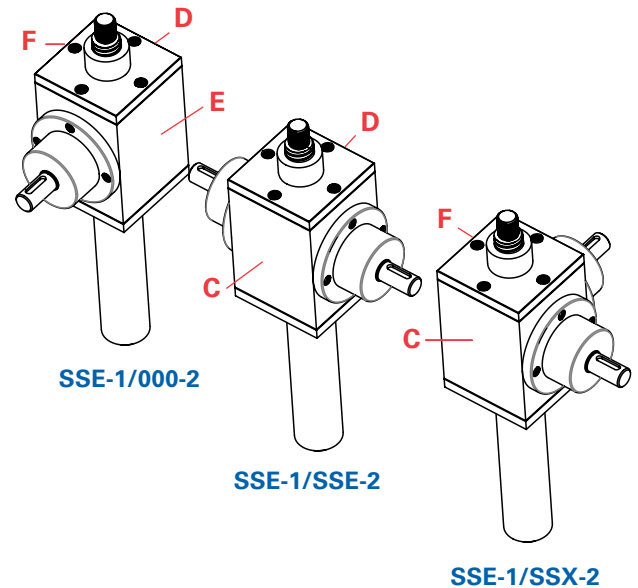

LUBRICATION

Unlike standard worm screw jacks, Nook/Thomson bevel screw jacks are half filled with oil. This requires venting to relieve pressure that can build up during the operation of the jack. The bevel jacks come with four port locations on a common face, which is typically located opposite the input shaft. The jacks will be shipping oil filled with one oil vent and four oil plugs. Once installed remove the upper port and replace with the supplied vent.

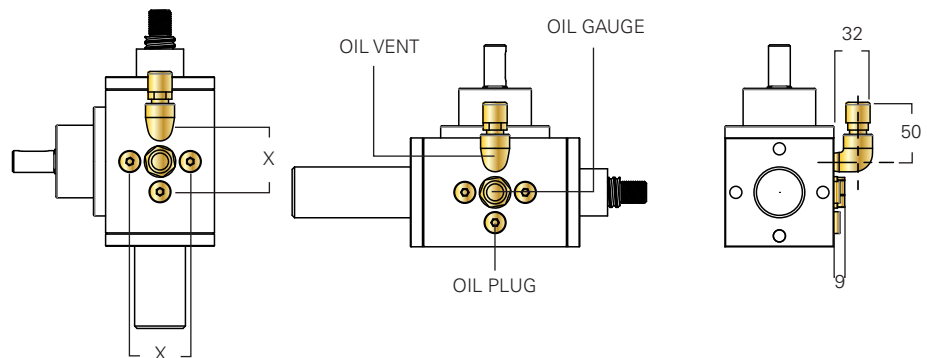

MODEL	X
G1	50
G2	90
G3	180

DESIGN CONSIDERATIONS (CONTINUED)

For multiple jack arrangements, total kilowatts required depends on horsepower per jack, number of jacks, the efficiency of the gear box(es) and the efficiency of the arrangement.

Arrangement efficiency –

- Two jacks = 95%
- Three jacks = 90%
- Four jacks = 85%
- Six to eight jacks = 80%

The efficiency of each miter gearbox is 90%. Therefore, motor kilowatts requirement for the arrangement:

$$\text{Kilowatts Arrangement} = \frac{\text{kW per jack} \times \text{Number of jacks}}{\text{Arrangement Efficiency} \times \left(\text{Gearbox Efficiency} \right)^N}$$

where N = Number of gearboxes.

If the application duty cycle exceeds the allowable duty cycle as illustrated on pages 8 and 9 for the jack selected, several solutions are possible.

- Use a larger jack model to increase the maximum allowable horsepower.
- Use a Ball Screw Jack to reduce the power required to do the same work.
- Operate at a lower input speed.
- Use a right angle reducer to bring the power requirement within acceptable limits.

When utilizing multiple jack arrangements, the input torque to the first jack must be considered. It is recommended that the number of jacks driven through a single jack input be limited to a maximum of three jacks. Consult Nook/Thomson Application Engineers for arrangements where more than three jacks will be driven through a single jack input.

INPUT ROTATION

The input shafts can either rotate CW or CCW with respect to extending the lift shaft. Care must be taken when using multiple jack arrangements. Bevel Jacks with two input shafts will rotate in opposing direction with respect to their common axis.

U ARRANGEMENT

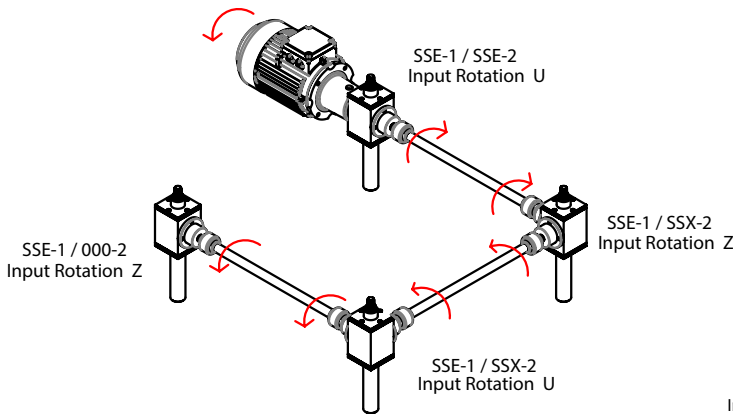

H ARRANGEMENT

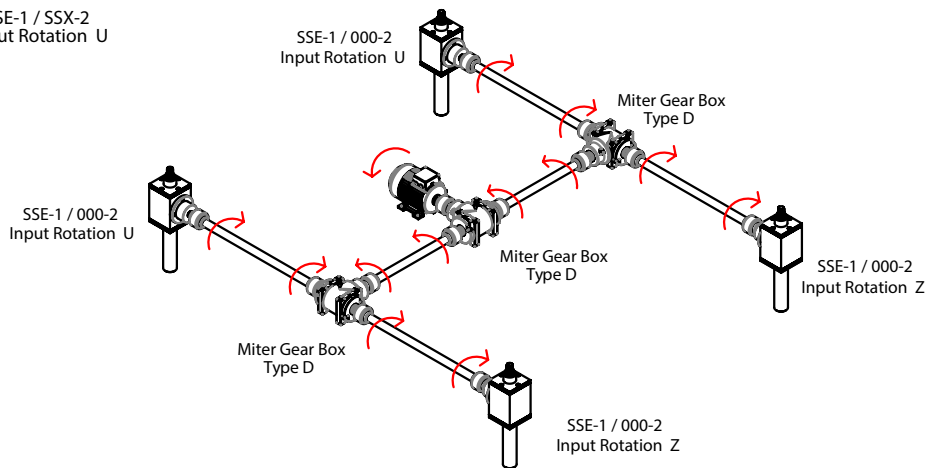

I ARRANGEMENT

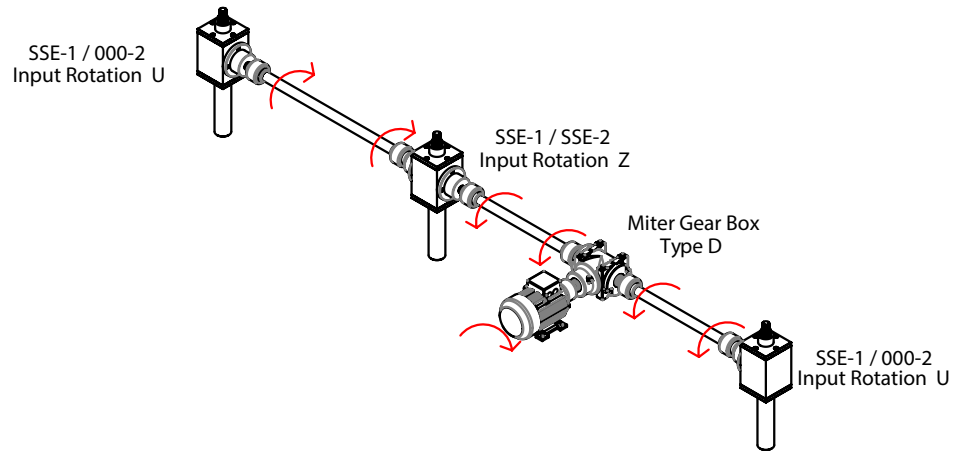

T ARRANGEMENT

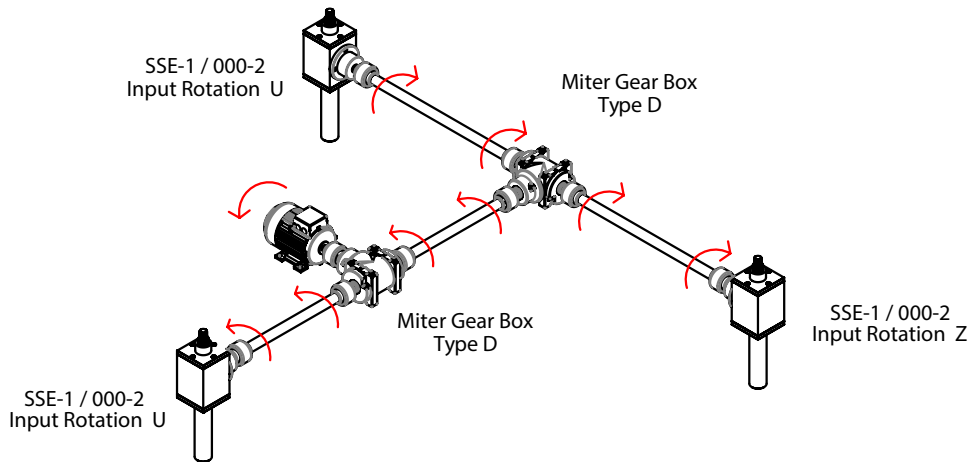

G1-BSJ

G1-BSJ TOP VIEW (2:1 GEAR RATIO)

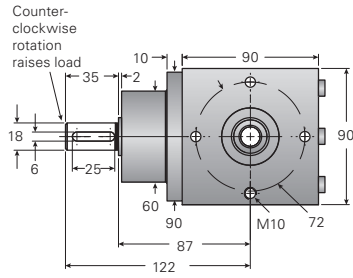

G1-BSJ TOP VIEW (3:1 GEAR RATIO)

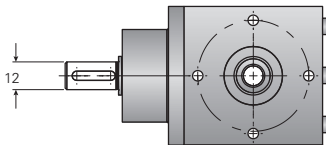

G1-BSJ-U UPRIGHT

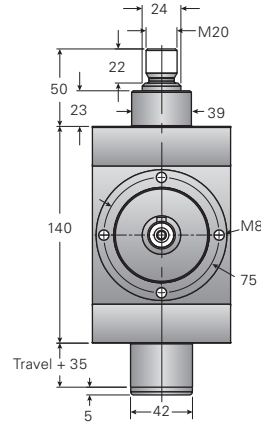

MODEL	Gear Ratio	Capacity (kN)	Raise for One Turn of Worm (mm)	Max Input Torque (N.m)
G1-BSJ	2:1	15	2.5	50
	3:1	15	1.6	50

Screw Specs:

Screw Dia: 25 mm

Lead: 5 mm

Start torque = 1.5 × Running Torque

Approximate weight (kg)

“0” Travel: 7.7

Per inch travel: 0.32

Grease: 0.22

Caution: Jack is self-lowering. Lifting screw must be secured to prevent rotation for non-keyed units.

G2 BSJ

G2-BSJ TOP VIEW

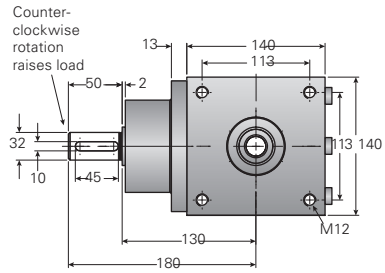

G2-BSJ-U UPRIGHT

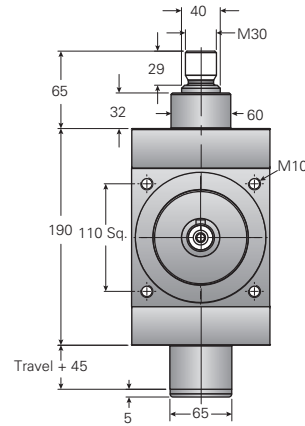

MODEL	Gear Ratio	Capacity (kN)	Raise for One Turn of Worm (mm)	Max Input Torque (N·m)
G2-BSJ	2:1	50	2.5	175
	3:1	50	1.6	175

Screw Specs:

Screw Dia: 40 mm

Lead: 5 mm

Start torque = 1.5 × Running Torque

Approximate weight (kg)

 "0" Travel: 15.9

 Per 100mm travel: 0.81

 Grease: 0.45

Caution: Jack is self-lowering. Lifting screw must be secured to prevent rotation for non-keyed units.

G2-BSJ-UR

UPRIGHT ROTATING

For ordering, specify "L" dimension
L(min) = Travel + 331

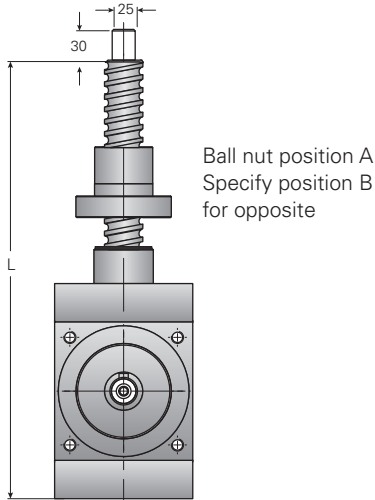

G2-BSJ-UK

INVERTED KEYED

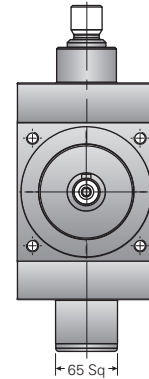

Backdrive holding torque (N·m)	Torque to raise 1 kN (N·m)	Tare Drag Torque (N·m)	Dynamic Load Ca (kN)
9.64	0.53	2.30	23.8
5.44	0.34	2.20	23.8

G2-BSJ BALL NUT AND FLANGE

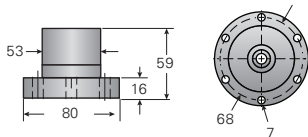

MALE CLEVIS

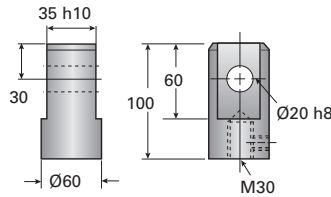

TOP PLATE

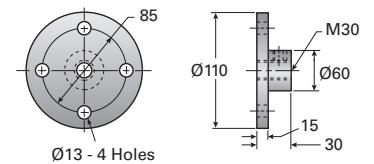

TRUNION PLATE

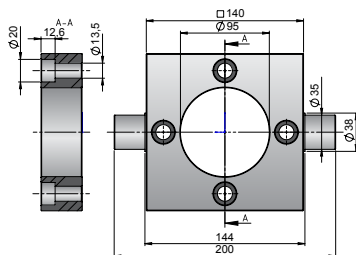

MALE CLEVIS

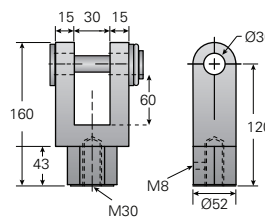

ROD-EYE CLEVIS

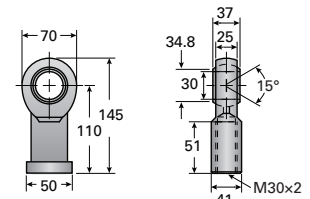

G2HL BSJ

G2HL-BSJ TOP VIEW

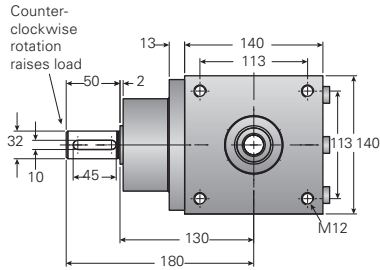

G2HL-BSJ-U UPRIGHT

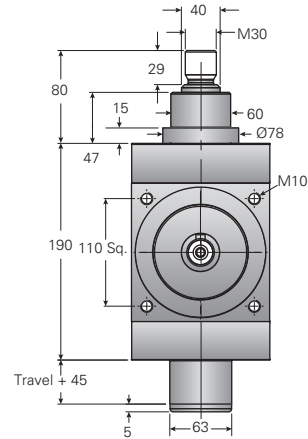

MODEL	Gear Ratio	Capacity (kN)	Raise for One Turn of Worm (mm)	Max Input Torque (N·m)
G2HL-BSJ	2:1	50	5	175
	3:1	50	3.33	175

Screw Specs:

Screw Dia: 32 mm

Lead: 10 mm

Start torque = 1.5 × Running Torque

Approximate weight (kg)

“0” Travel: 15.9

Per 100mm travel: 0.81

Grease: 0.45

Caution: Jack is self-lowering. Lifting screw must be secured to prevent rotation for non-keyed units.

G2HL-BSJ-UR

UPRIGHT ROTATING

For ordering, specify "L" dimension
L(min) = Travel + 331

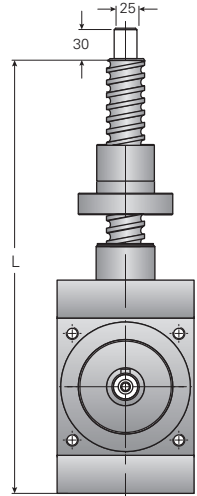

Ball nut position A
Specify position B
for opposite

G2-BSJ-IK & G2L-BSJ-IK
INVERTED KEYS

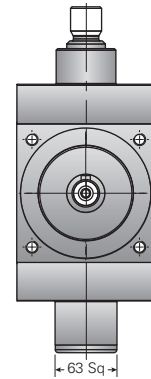

Backdrive
holding torque (N·m)

Torque to raise 1 kN
(N·m)

Tare Drag Torque
(N·m)

Dynamic Load
Ca (kN)

21.57

1.06

2.30

33.4

13.70

0.71

2.20

33.4

G2-BSJ-UR & G2HL-BSJ-UR BALL NUT AND FLANGE

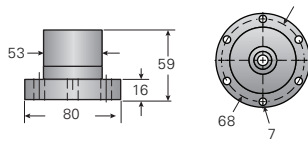

MALE CLEVIS

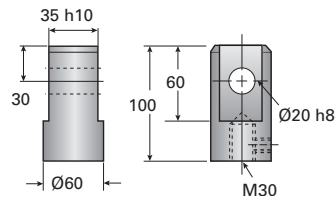

TOP PLATE

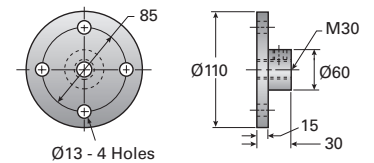

TRUNION PLATE

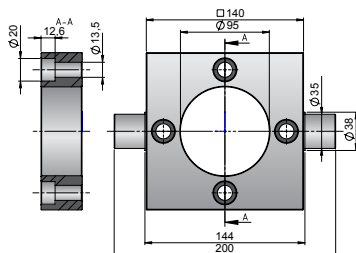

FEMALE CLEVIS

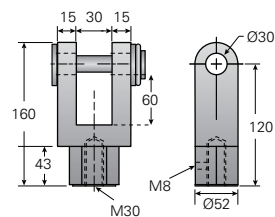

ROD-EYE CLEVIS

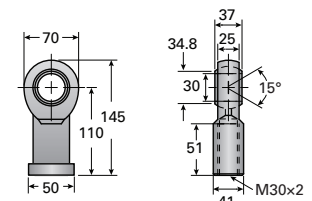

G3 BSJ

G3-BSJ TOP VIEW (2:1 GEAR RATIO)

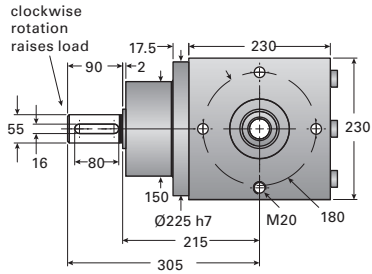

G3-BSJ TOP VIEW (3:1 GEAR RATIO)

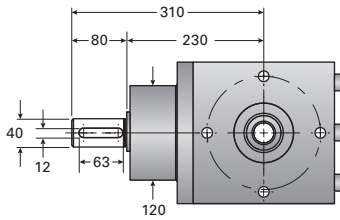

G3-BSJ-U UPRIGHT

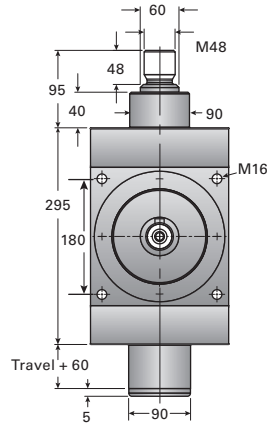

MODEL	Gear Ratio	Capacity (kN)	Raise for One Turn of Worm (mm)	Max Input Torque (N-m)
G3-BSJ	2:1	90	5	1600
	3:1	90	3.33	1600

Screw Specs:
Screw Dia: 63 mm
Lead: 10 mm
 Start torque = 1.5 × Running Torque
 Approximate weight (kg)
 "0" Travel: 36.3
 Per 100mm travel: 2.12
 Grease: 1

Caution: Jack is self-lowering. Lifting screw must be secured to prevent rotation for non-keyed units.

G3-BSJ-UR

UPRIGHT ROTATING

For ordering, specify "L" dimension
L(min) = Travel + 514

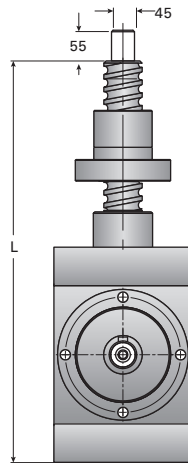

Ball nut position A
Specify position B
for opposite

G3-BSJ-UK
KEYED

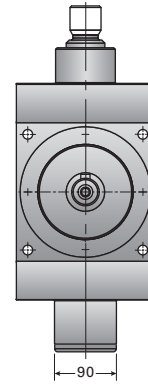

Backdrive holding torque (N·m)	Torque to raise 1 kN (N·m)	Tare Drag Torque (N·m)	Dynamic Load Ca (kN)
38.57	1.06	4.4	76.0
31.47	0.71	4.3	76.0

G3-BSJ BALL NUT AND FLANGE

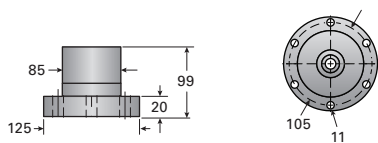

MALE CLEVIS

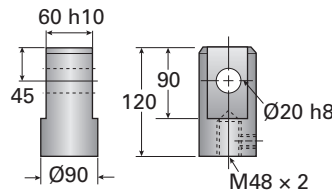

TOP PLATE

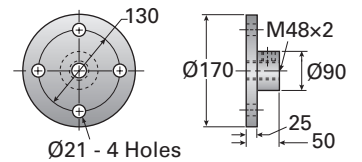

TRUNION PLATE

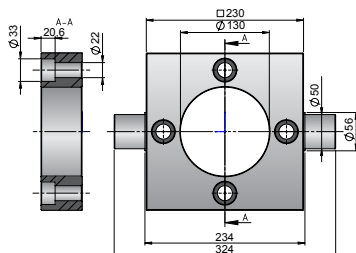

FEMALE CLEVIS

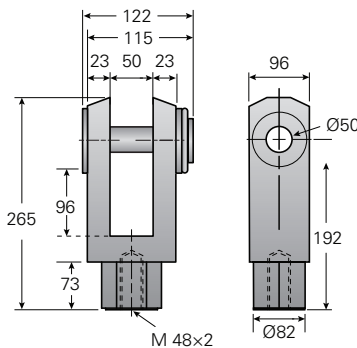

ROD-EYE CLEVIS

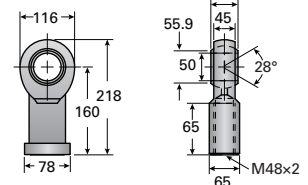

G1-MSJ

G1-MSJ TOP VIEW (2:1 GEAR RATIO)

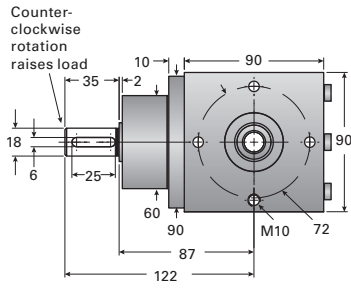

G1-MSJ TOP VIEW (3:1 GEAR RATIO)

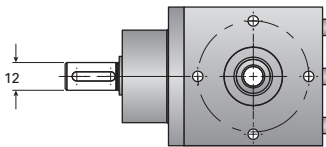

G1-MSJ-U UPRIGHT

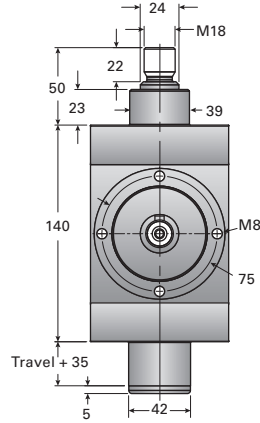

MODEL	Gear Ratio	Capacity (kN)	Raise for One Turn of Worm (mm)	Max Input Torque (N·m)
G1-MSJ	2:1	20.6	2.5	50
	3:1	20.6	1.6	50

Screw Specs:
Screw Dia: 24 mm
Lead: 5 mm
 Start torque = 1.5 × Running Torque
 Approximate weight (kg)
 "0" Travel: 7.7
 Per inch travel: 0.32
 Grease: 0.22

G1-MSJ-UR

UPRIGHT ROTATING

For ordering, specify "L" dimension
L(min) = travel + 247

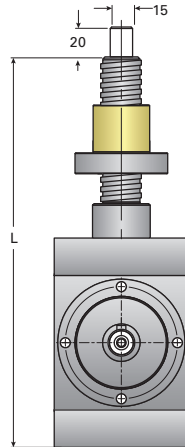

Travel nut position A
Specify position B
for opposite

G1-MSJ-UK

KEYED

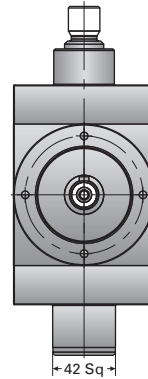

Backdrive holding torque (N·m)	Torque to raise 1 kN (N·m)	Tare Drag Torque (N·m)
1.06	0.88	1.80
0.13	0.57	1.70

G1-MSJ TRAVEL NUT AND FLANGE

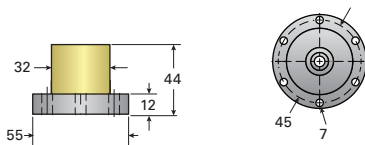

MALE CLEVIS

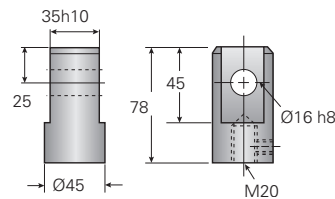

TOP PLATE

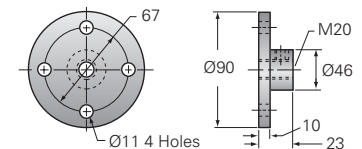

TRUNION PLATE

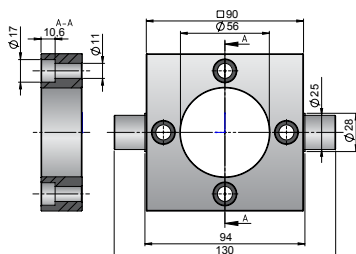

FEMALE CLEVIS

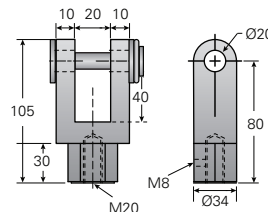

ROD-EYE CLEVIS

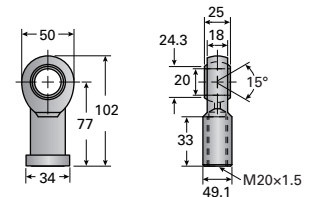

G2 MSJ

G2-MSJ TOP VIEW

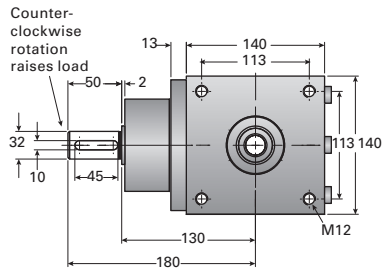

G2-MSJ-U UPRIGHT

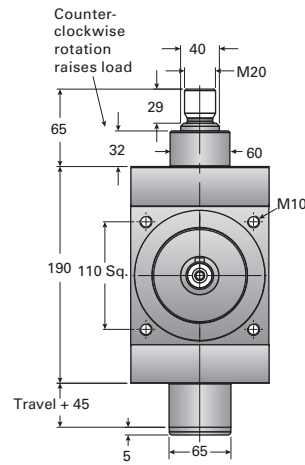

MODEL	Gear Ratio	Capacity (kN)	Raise for One Turn of Worm (mm)	Max Input Torque (N-m)
G2-MSJ	2:1	44.5	3.5	175
	3:1	44.5	2.3	175

Screw Specs:

Screw Dia: 40 mm

Lead: 7 mm

Start torque = 1.5 × Running Torque

Approximate weight (kg)

“0” Travel: 15.9

Per 100mm travel: 0.81

Grease: 0.45

G2-MSJ-UR

UPRIGHT ROTATING

For ordering, specify "L" dimension
 $L(\text{min}) = \text{travel} + 345$

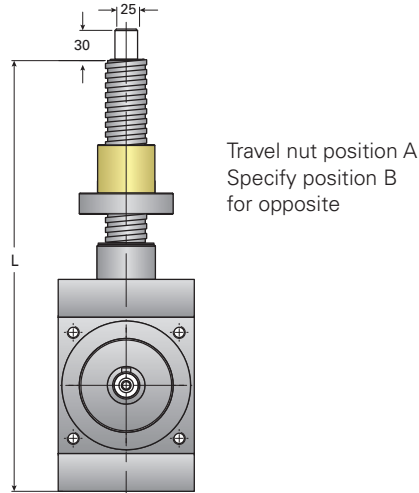

G2-MSJ-UK

INVERTED KEYS

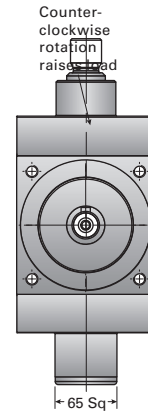

Backdrive holding torque (N·m)	Torque to raise 1 kN (N·m)	Tare Drag Torque (N·m)
6.61	1.39	2.30
3.73	0.93	2.20

G2-MSJ TRAVEL NUT AND FLANGE

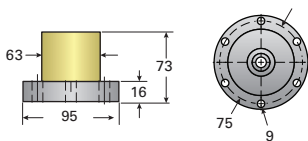

MALE CLEVIS

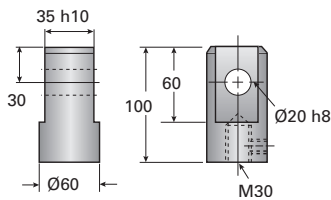

TOP PLATE

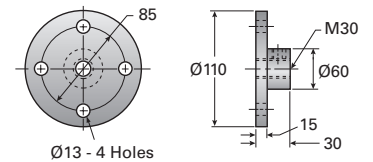

TRUNION PLATE

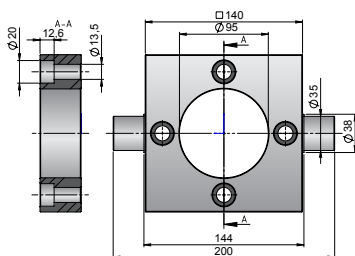

MALE CLEVIS

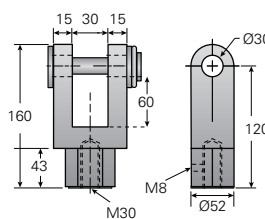

ROD-EYE CLEVIS

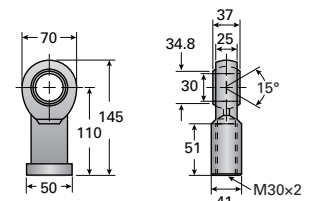

G3 MSJ

G3-MSJ TOP VIEW (2:1 GEAR RATIO)

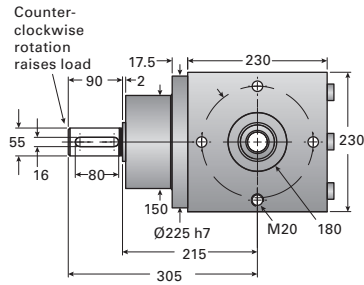

G3-MSJ TOP VIEW (3:1 GEAR RATIO)

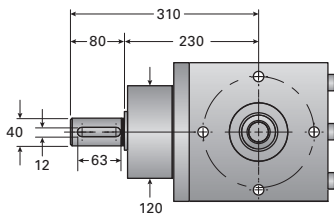

G3-MSJ-U UPRIGHT

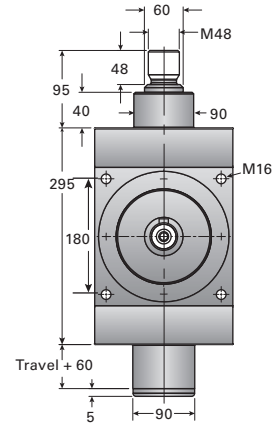

MODEL	Gear Ratio	Capacity (kN)	Raise for One Turn of Worm (mm)	Max Input Torque (N·m)
G3-MSJ	2:1	117	4.5	1600
	3:1	117	3	1600

Screw Specs:

Screw Dia: 63 mm

Lead: 10 mm

Start torque = 1.5 × Running Torque

Approximate weight (kg)

“0” Travel: 36.3

Per 100mm travel: 2.12

Grease: 1

G3-MSJ-UR

UPRIGHT ROTATING

For ordering, specify "L" dimension
L(min) = travel + 514

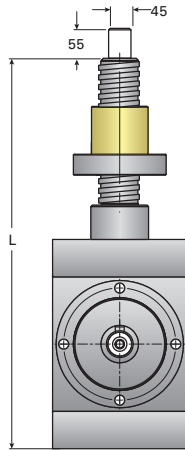

Travel nut position A
Specify position B
for opposite

G3-BSJ-UK

KEYED

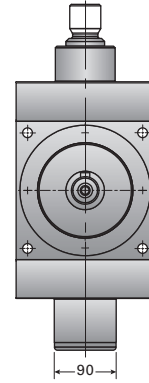

Backdrive holding torque (N·m)	Torque to raise 1 kN (N·m)	Tare Drag Torque (N·m)
13.65	2.05	4.40
7.73	1.36	4.30

G3-MSJ TRAVEL NUT AND FLANGE

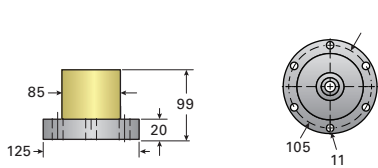

MALE CLEVIS

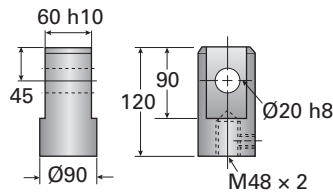

TOP PLATE

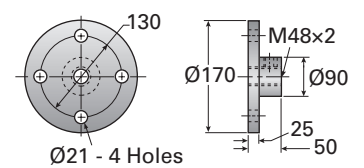

TRUNION PLATE

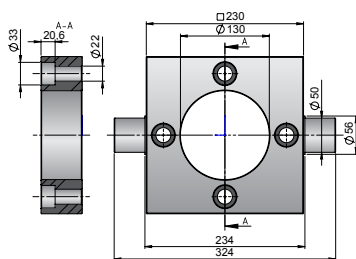

FEMALE CLEVIS

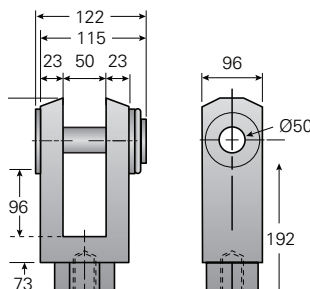

ROD-EYE CLEVIS

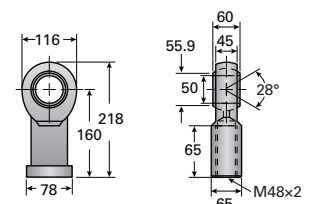

UNIT CONVERSION

ENGLISH TO METRIC		METRIC TO ENGLISH	
Length	Torque	Length	Torque
1 ft = 304.8 mm	1 lb-ft = .001356 kN·m	1 mm = .00328 ft	1 kN·m = 737.3 lb-ft
1 ft = .3048 m	1 lb-ft = 1.356 N·m	1 m = 3.28 ft	1 N·m = .737 lb-ft
1 ft = .0003048 km	1 lb-ft = 135.6 N·cm	1 km = 3821 ft	1 N·cm = .00737 lb-ft
1 in = 25400 m	1 lb-ft = 1356 N·mm	1 m = .0000394 in	1 N·mm = .000737 lb-ft
1 in = 25.4 mm	1 lb-ft = .1383 kgf·m	1 mm = .03937 in	1 kgf·m = 7.23 lb-ft
1 in = .0254 m	1 lb-in = .000113 k·m	1 m = 39.37 in	1 kN·m = 8847.2 lb-in
1 in = .0000254 km	1 lb-in = .113 N·m	1 km = 39370 in	1 N·m = 8.847 in-ft
	1 lb-in = .01152 kgf·m		1 kgf·m = 86.8 lb-in
Weight/Force	Rail Weight	Weight/Force	Rail Weight
1 lb = .454 kg	1 lb/in = 17.9 kg/m	1 kg = 2.205 lb	1 kg/m = .056 lb/in
1 lb = .454 kgf	1 lb/ft = 1.49 kg/m	1 kgf = 2.205 lb	1 kg/m = .672 lb/ft
1 lb = 4.45 N		1 N = .225 lb	
1 lb = .00445 kN		1 kN = 224.8 lb	
Speed		Speed	
1 ft/sec = .3048 m/sec		1 m/sec = 3.28 ft/sec	
1 in/sec = .0254 m/sec		1 m/sec = 39.37 in/sec	

LUBRICANTS

LUBRICATION

ActionJac™ Bevel Gear Screw Jacks require lubrication to operate efficiently and with maximum life.

Lubricants containing additives such as molydisulfide or graphite should not be used.

Bevel gear screw jack housings use a synthetic oil ISO VG 220 or equivalent.

Ball Screw models need only a light film of lubricant on the lift shaft for most applications. Nook/Thomson E-900 Ball Screw

Lubricant may be applied with a cloth or spray. Operating a Ball Screw Jack lift shaft without lubrication will result in a ninety percent reduction in life.

Lubrication intervals for the lift shaft of Machine Screw models are determined by the application. Proper lubrication with E-100 spray lube or PAG-1 grease must be provided to achieve satisfactory service life. It is required that screw assemblies are lubricated often enough to maintain a film of lubricant on the screw.

MACHINE SCREW JACK LIFT SHAFT LUBRICANT

LIFT SHAFT LUBRICANT	USAGE	NLGI GRADE NUMBER	GELLING AGENT	TEMP. RANGE	NET CONTENTS PER UNIT	PART NO.	NET WEIGHT
PAG-1 Grease	Acme Screws and Nuts	2	Calcium	15°F to 400°F	1	NLU-1001	16 oz
					Case of 12	NLU-2001	—
E-100 Spray	Acme Screws and Nuts	2	Calcium	15°F to 400°F	1	NLU-1002	12 oz
					Case of 12	NLU-2002	—



BALL SCREW JACK LIFT SHAFT LUBRICANT

LIFT SHAFT LUBRICANT	USAGE	NLGI GRADE NUMBER	GELLING AGENT	TEMP. RANGE	NET CONTENTS PER UNIT	PART NO.	NET WEIGHT
E-900 Spray	Ball Screws and Nuts	N/A	N/A	-65°F to 350°F	1	NLU-1003	12 oz
					Case of 12	NLU-2003	—
E-900L Oil	Ball Screws and Nuts	N/A	N/A	-65°F to 350°F	1	NLU-1004	32 oz
					Case of 12	NLU-2004	—





Also find us at:



Nook_Bevel_Gear_Screw_Jacks_BREN-0043-01 | 20221027KB
Specifications are subject to change without notice. It is the responsibility of the product user to determine the suitability of this product for a specific application. All trademarks property of their respective owners. ©2022 Thomson Industries, Inc.

4950 East 49th Street | Cleveland, OH 44125-1016 USA | 216.271.7900 | toll-free: 800.321.7800 | f: 216.271.7020 | email: nook@nookind.com